

EN/CN-A01

Filament Drying Station

Filament Drying Station

USER GUIDE

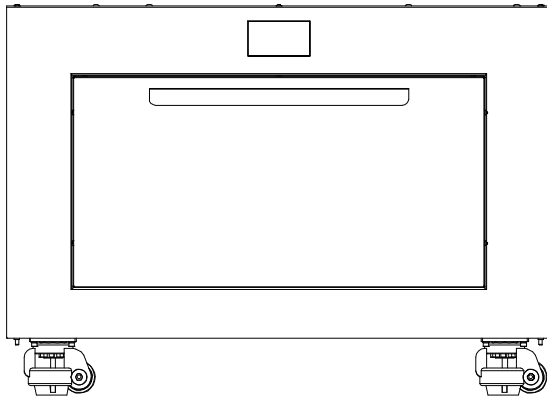

This guide is only applicable
to FLASHFORGE Filament Drying Station

Content

NOTICE	01
1. Introduction	03
1.1 - Product Introduction	03
1.2 - Packing List	03
1.3 - Equipment Parameter	04
1.4 - Combined Use	05
2. Equipment Operation Introduction	06
2.1 - Storage Function	06
2.2 - Drying Function	07
2.3 - Annealing Treatment	09
2.4 - Filament Drying Station Setting	10
3. Replace the Desiccant	12
4. Q&A	13
5. Support and Service	15

NOTICE

PLEASE STRICTLY FOLLOW ALL THE SAFETY WARNINGS AND NOTICES BELOW ALL THE TIME.

WORK ENVIRONMENT SAFETY

- ◆ Please keep the work table of the equipment clean and tidy.
- ◆ Please keep the equipment away from combustible gases, liquids and dust when working. The high temperature generated during the equipment operation may react with flammable liquids, gases, and airborne dust, thus causing fire.
- ◆ Children and untrained personnel are not allowed to operate the equipment alone.

ELECTRICAL SAFETY

- ◆ Be sure to ground the equipment. Do not modify the plug of the equipment.
- ◆ Ungrounded equipment/improperly grounded equipment/modified plug will inevitably increase the risk of electric leakage.
- ◆ Do not expose the equipment to damp or hot-sun environment. Humidity will increase the risk of electric leakage. Exposure to sunlight will accelerate the aging of plastic parts.
- ◆ Make sure to only use the power cord provided by Flashforge.
- ◆ Do not use the equipment during a thunderstorm.
Please shut down the equipment and unplug it if it is not in use for a long time.

PERSONAL SAFETY

- ◆ Do not touch the high-temperature position directly when the equipment is in operation!
- ◆ Do not operate the equipment while you are tired or under the influence of drugs, alcohol or medication!

ENVIRONMENT REQUIREMENTS

- ◆ The room temperature should be between 15°C and 30°C.
- ◆ The humidity should be between 20% and 70%.

EQUIPMENT PLACEMENT REQUIREMENTS

- ◆ The equipment must be placed in a dry and ventilated environment. At least a 10cm-distance must be reserved on the left side, right side and rear side of the equipment.

LEGAL STATEMENT

- ◆ The user has no right to make any modification to this user guide.
- ◆ Flashforge will not be responsible for any safety accidents caused by the disassembly or modification of the equipment by the customer. No one is allowed to modify or translate this guide without the permission of Flashforge.
- ◆ This guide is protected by copyright, and Flashforge reserves the right of the final interpretation of this guide.
- ◆ Flashforge reserves the right to modify the guide due to subsequent equipment upgrades.
- ◆ First Edition (March 2022)
Copyright © 2022 Zhejiang Flashforge 3D Technology Co., Ltd. All Rights Reserved.

1. Introduction

1.1 Product Introduction

1. Storage Drawer
2. Drawer Pull
3. Temperature Probe
4. Drawer Sealing Strip
5. Stop Block
6. Display Screen
7. Caster
8. Protective Cover
9. Drawer Slide
10. Rear Cover Plate
11. Power Switch
12. Power Outlet
13. Back Plate- 14. Air Inlet
- 15. Air Outlet

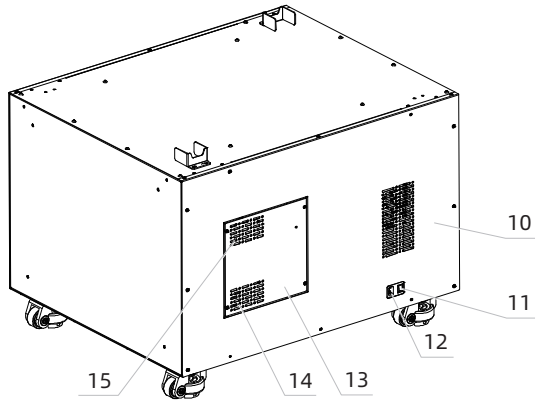
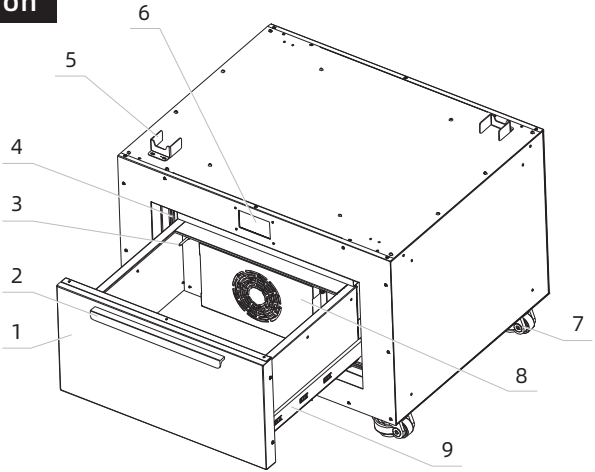

1.2 Packing List

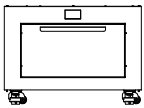

Filament
Drying Station

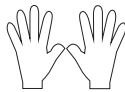

Heat Insulating
Gloves



Power Cord



Allen Wrench

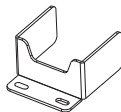

Stop Block*2



Screw*4

1.3 Equipment Parameter

Size	840x*675y*600z mm (with casters)
Screen	4.3-inch touch screen
Language	Chinese/English/Japanese/German/French/Korean
Maximum drying temperature	120°C
Desiccant service time	1 year
Desiccant capacity	800g
Storage humidity control range	10-20%
Internal storage size	500*375*200 mm(WxDxH)
Power	500W
Bearing weight	120kg
Package size	980*780*830 mm
Package weight	100kg
Power during storing	Average: 30W; Maximum: 35W
Power during drying (12hrs, 120°C)	Average: 100W; Maximum: 500W
Power consumption (drying for 12hrs at 120°C)	About 1.4KWh
Applicable material	Moisture-sensitive materials:
	PVA / PVOH / BVOH / PVB / PA6 / PA12 / PA66 /
	PC / ABS / ABS Pro / HIPS / ASA / PET / PETG /
	WOOD / Metal Fill
	Moisture-sensitive fiber reinforced materials:
	PA6-CF / PA12-CF / PA66-CF / PET-CF / PP-CF /
	ASA-CF / PETG-CF / PLA-CF / PPS-CF / PA6-GF /
	PLA-GF

1.4 Combined Use

This filament drying station can be used together with Creator 4 series equipment, which can be placed above the filament drying station.

After finishing placing, tighten the installation fixing block with screws.

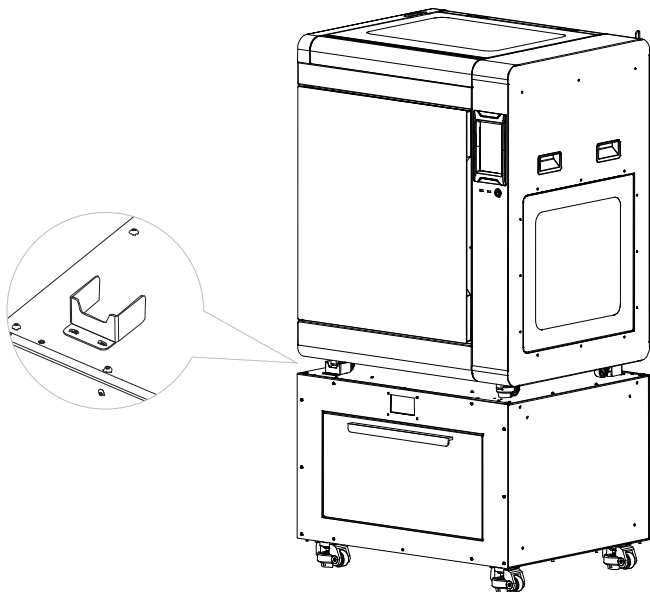

2. Equipment Operation Introduction

Connect the power supply, turn on the power switch, and start the machine;
If the filament has absorbed moisture, it is necessary to enable the drying function to dry the filament;
If the filament has not absorbed moisture, only the storage function needs to be enabled to store the filament.

2.1 Storage Function

The default storage range of the equipment is less than 15%; After starting up the equipment, the storage function is enabled by default;
The interface will display the current temperature and humidity of the filament chamber. The humidity value will change as the storage function is turned on until the humidity reaches the set humidity storage range.

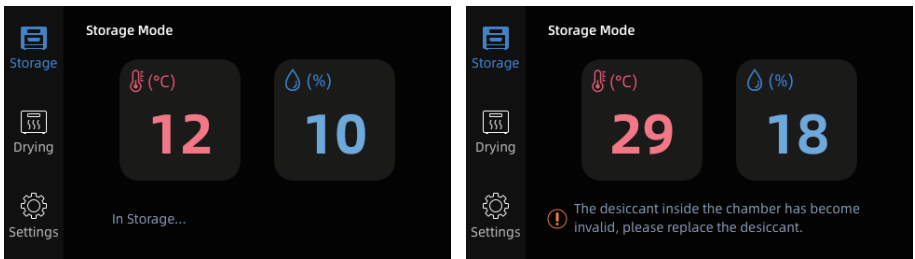

It adopts the renewable desiccant, which can be recycled, for storage; When the auto cycle function is enabled and the equipment detects that the desiccant is moisture-saturated, the humidity of the chamber will become higher, and at this time, the desiccant dehumidification function will be enabled automatically, so that the desiccant can be dried again. At this time, it is normal that the humidity display value may fluctuate.

There will be corresponding prompts in the interface.



Please be sure to keep the door closed during storage.

2.2 Drying Function

Click on the drying function bar and select the filament to be dried. The default drying time and temperature has been set already when leaving the factory.

The interface will display the target drying temperature and actual temperature, total drying time and remaining time and chamber humidity value.

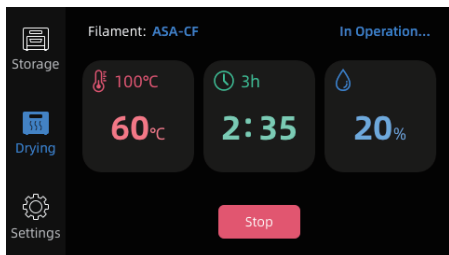
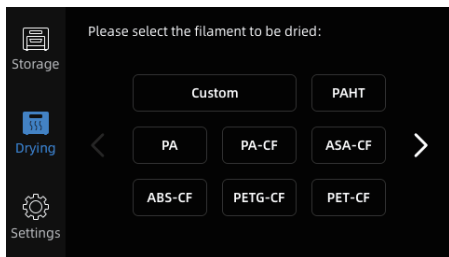

Users can also customize the material and set the required drying time and temperature for it.

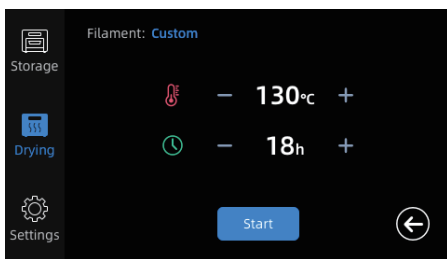
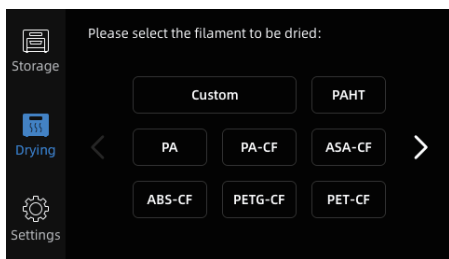

⚠ Note

- Please be sure to keep the door closed during drying;
- If the hot melt characteristics of the materials differ greatly, they can not be dried at the same time. For example, PLA material, of which the softening temperature is 53°C, is not suitable for drying together with high-temperature resistant materials such as PC and PA.
- The filament spool material is usually ABS/PC-ABS/PC material. If the temperature is too high, the filament spool may be deformed. For filaments shipped after May 2022, Flashforge will adopt PC-ABS material for the spool.
- Note that if the temperature displayed by the filament drying station exceeds 50°C when taking the filament out, please wear heat insulating gloves to avoid scalding.

The following softening temperatures of filaments are for reference only:
The heat deflection temperature varies under different experimental conditions.

Filament	Heat Deflection Temperature(°C)
PA12-CF15(9891BK)	90
PA6-CF10	200
PA66-CF10	150
PET-CF15(9780BK)	100
PETG-CF10	70
PLA-CF10	60
PC-ABS	123
PA6/66	85
PA1010	100
PAHT	90
PC	105
PP	113
HIPS	98
PLA PRO	53
PLA	53
PETG PRO	68
PETG	74
ABS PRO	103
PBT	127

2.3 Annealing Treatment

It is recommended that the engineering filaments should be annealed after finishing printing to eliminate the internal stress of the model, improve the properties of the model and slow down the second-time moisture absorption of the model. Place the filament in the filament drying station, enable the drying function and set the corresponding temperature and time, thus the annealing treatment is carried out.

Annealing treatment is recommended for the following materials:

PA, PAHT and PA12-CF should be annealed to improve the mechanical properties of the model samples.

Annealing conditions:

PA: Place the sample in the Filament Drying Station at 70°C and dry it for 2 hours.

PAHT: Place the sample in the Filament Drying Station at 70°C and dry it for 2 hours.

PA12-CF: Place the sample in the Filament Drying Station at 80°C and dry it for 6 hours.

Comparison of material properties before and after annealing (this data is for reference only, and it varies under different testing environments and methods)

Comparison of tensile properties of PA, PAHT and PA12-CF before and after annealing (Mpa)

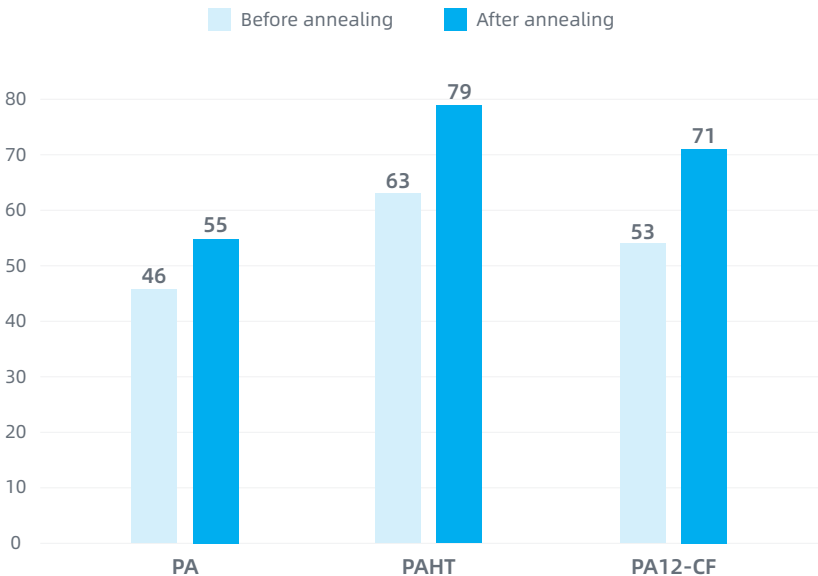

2.4 Filament Drying Station Setting

Storage Humidity Range

The settings include the storage humidity range, which can be used to set the humidity range for material storage.

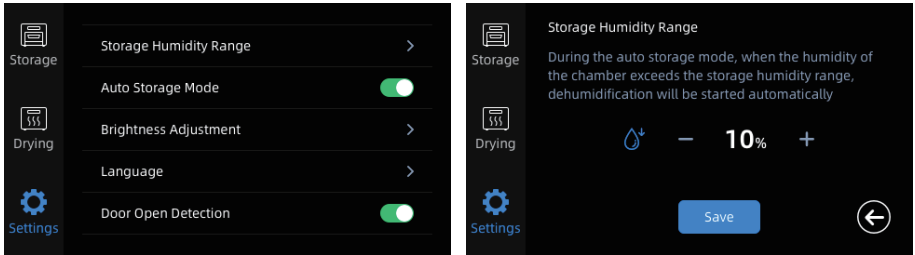

Recommended humidity for material storage

	PVA	PA	TPU	PLA	ABS	PETG	PC	PBT	Fiber Composite Material
<10%	Good	Good	Good	Good	Good	Good	Good	Good	Good
<15%	Medium	Good	Good	Good	Good	Good	Good	Good	Good
<20%	Poor	Medium	Medium	Good	Good	Good	Good	Good	Medium
>25%	Poor	Poor	Poor	Medium	Medium	Medium	Medium	Medium	Poor

Auto Storage Mode

It is turned on by default. When it is turned off, the desiccant dehumidification function will not be started even when the desiccant in the chamber has become moisture-saturated. Therefore, the storage function will fail as the desiccant becomes invalid.

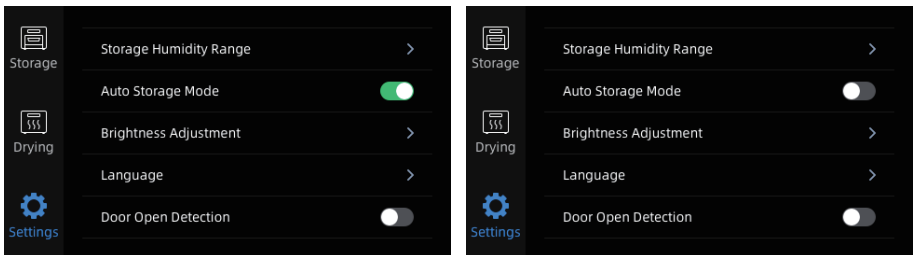

Brightness Adjustment

Adjust the screen brightness: the larger the number, the brighter the brightness.



Language

The equipment supports seven languages: Chinese, English, Japanese, German, French, Spanish and Korean.

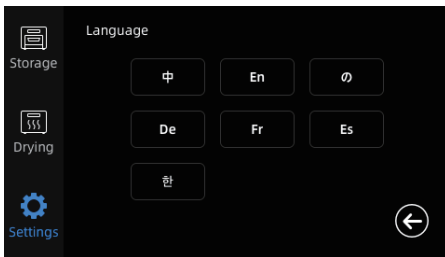

! Note

Please restart after switching languages.

Door Open Detection

If the door open detection function is turned on: when the equipment door is opened, the drying function and storage function will not be enabled in order to prevent shortening the service life of desiccant.

If the door open detection function is turned off: even if the equipment door is opened, the drying function and storage function can still be enabled. However, this will increase energy consumption.

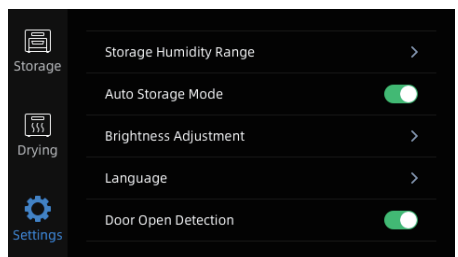
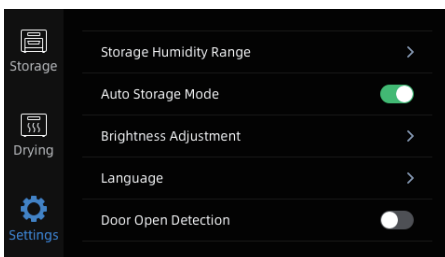

3. Replace the Desiccant

When the equipment gives a prompt to suggest replacing the desiccant, it means that the service life of the desiccant has arrived, and the desiccant needs to be replaced manually by the user.

The operation method is as follows:

- Turn off the power supply. Please note that the filament drying station should be in the cooling state to avoid accidental injury caused by high temperature;
- Open the back plate (unscrew the four screws);
- Loosen the sheet metal screws of the regeneration box with an Allen wrench, and remove the sheet metal, the sheet metal sealing ring and the heat insulation foam;
- Loosen the four screws shown in the figure with an Allen wrench;
Turn over the aluminum substrate assembly in the direction of the arrow, and take out
- the desiccant bag inside. Put in a new desiccant bag;
- Re-lock each screw back in place.

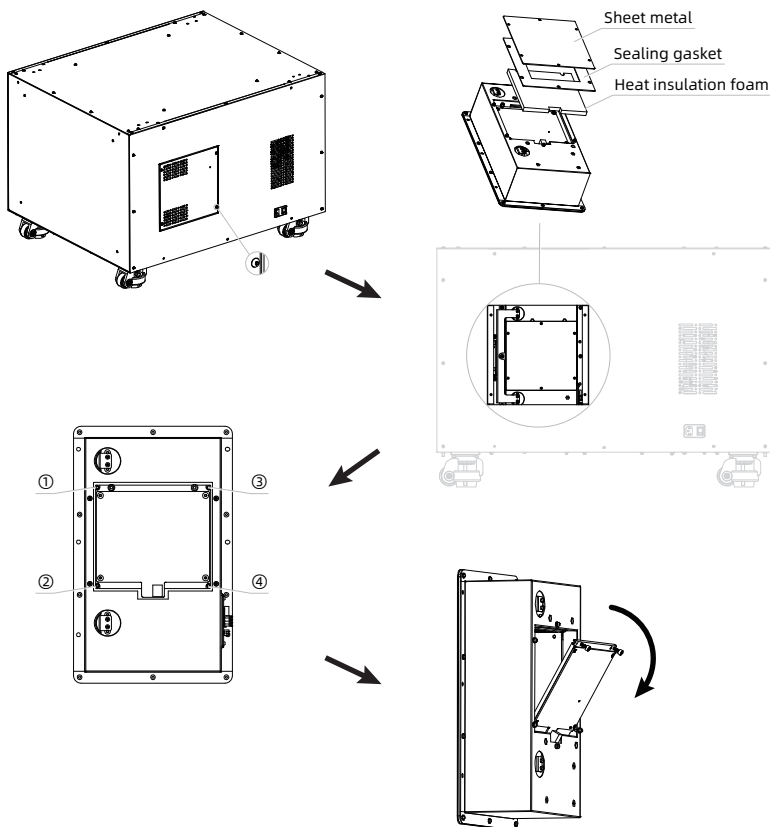

4. Q&A

Q: How often do you need to change the desiccant?

A: Generally, it can be recycled for 1-year use. If the desiccant is invalid, the equipment will prompt the user.

Q: Do filaments have to be dried before printing?

A: Standard filaments (materials with water absorption less than 0.3) do not necessarily need to be dried, but carbon fiber and glass fiber composite filaments are recommended to be dried before printing.

Q: Is the drying time of each material adjustable?

A: The drying time and temperature of related materials have been set in the equipment. However, the user can also adjust them according to the actual situation.

Q: Can the drying function and the storage function be used together?

A: No. Because it is in the same chamber, and the chamber will be heated to the set temperature during drying.

Q: Can different materials be put together for drying?

A: Not necessarily.

If the material characteristics are similar, such as PA12-CF and PA6-CF, they can be dried at the same temperature for 8 to 12 hours. If the temperature resistance characteristics of materials are far different, they can not be dried together. For example, materials such as PLA and PC; The heat deflection temperature of PLA is only about 55°C, therefore, too high a temperature will make PLA material deform.

Q: Can different materials be put for drying or storage?

A: As long as the humidity setting is kept low for storage, different materials can be put for storage.

During drying, because of the different heat deflection temperatures of materials, materials with different characteristics can not be put into the filament drying station for drying together.

Q: What happens when the desiccant is in the regenerative cycle mode?

A: At this time, the equipment is dehumidifying the desiccant to achieve the purpose of reuse. At this time, the humidity data may rise.

Q: Is there a door sensor function?

A: There is a door sensor function. If the door open detection function is turned on, the drying and automatic storage (drying) functions will be enabled only when the door is closed tightly. It is also feasible to turn off the door detection function and then there will be no further detection of whether the door is closed or not.

Q: Is it very power-consuming to keep the filament drying station on for a long time?

A: The power consumption will be high only in the drying mode, while there is almost no power consumption in the storage mode.

Q: What is the power consumption of the filament drying station drying for 12 hours?

A: When at room temperature, the target drying temperature is set at 120°C, the power consumption is about 1.4KWh.

Q: How long is the estimated time for the indoor humidity to drop from 50% to 10%?

A: It will take about half an hour to reduce the indoor humidity from 50% to 10%.

Q: How does the door detection sensor affect the functions of the equipment?

A: If the door detection is not triggered (the door is not closed properly), the equipment will not give any prompt, and will not carry out the storage mode or the drying mode. It is necessary to ensure whether the door is closed properly.

When the door detection function is turned off in the settings, the drying and storage functions will be enabled whether the door is closed properly or not.

5. Support and Service

Flashforge team is on standby and ready to help you with any challenges you may have with your 3D printer. If the issues or questions are not covered in this User Guide, you can seek for solutions on our official website or contact us via telephone.

There are solutions and instructions to common issues that can be found in our knowledge base. Have a look first as most basic questions are answered there.
<http://www.flashforge.com>

The Flashforge support team can be reached by e-mail or phone between the working hours of 8:00 a.m. to 5:00 p.m. PST Monday through Saturday. In case you contact us during off-duty time, your inquiry will be answered the following business day.

Facebook Official Group Address: Flashforge Official User Group

Email: support@flashforge.com

Address: No.518 XianYuan Road, Jinhua City, Zhejiang Province, China

Note: Please provide the product serial number which is the barcode at the back of the Filament Drying Station before contacting our after-sales department.





Follow us

Zhejiang Flashforge 3D Technology Co., Ltd.

Address: No.518 XianYuan Road, Jinhua City, Zhejiang Province, China

Service Hotline: +86 579 82273989

support@flashforge.com