

Tiertime Filament Dryer

Instruction Manual

PRO

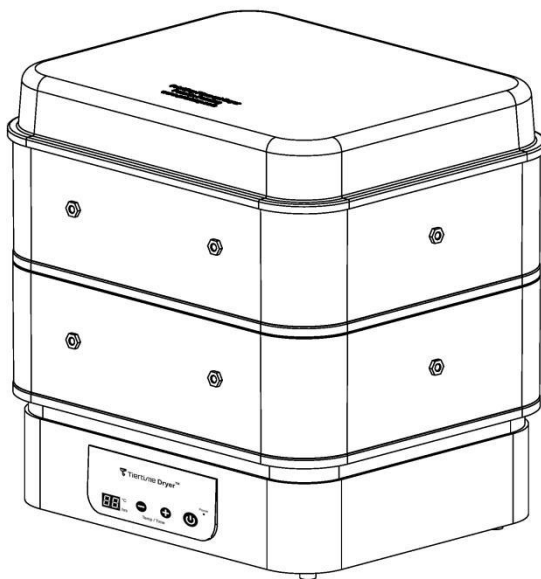

MODELS:

FD2003-120 (110-120VAC, 60Hz, 300W)

FD2003-220 (220-240VAC, 50Hz, 300W)

THANK YOU FOR PURCHASING THE PRINTDRY FILAMENT DRYER. BEFORE OPERATING, PLEASE MAKE SURE YOUR ELECTRICAL VOLTAGE MATCHES THE DRYER MODEL. PLEASE ALSO READ, UNDERSTAND AND FOLLOW THESE INSTRUCTIONS. BE SURE TO SAVE THIS BOOKLET FOR FUTURE REFERENCE.

Version: 2020-08

1. IMPORTANT SAFEGUARDS

When using an electrical device, basic safety precautions should always be followed, including the following:

- Read all instructions before using the Tiertime filament dryer (hereinafter referred as the "dryer").
- Always use a heat resistant surface.
- **DO NOT** touch hot surfaces.
- To protect against electrical hazards, **DO NOT** immerse cord, plug or the dryer in water or any other liquid. **DO NOT** switch the dryer ON if surfaces are wet.
- Do not allow children to use the dryer, close supervision is necessary when the dryer is used near children.
- Unplug from outlet when not in use and before cleaning. Allow to cool before putting on or taking off parts.
- **DO NOT** operate the dryer with a damaged cord or plug or after the dryer malfunctions, or has been damaged in any manner. Return the dryer to the manufacturer for examination, repair or adjustment. See Warranty section.
- The use of accessories/attachments not recommended may cause hazards.
- **DO NOT** use outdoors.
- **DO NOT** let cord hang over edge of table or counter, or touch hot surfaces.
- **DO NOT** place on or near a hot gas or electric burner, or in a heated oven.
- **DO NOT** block the air intakes or exhaust in any manner.
- **DO NOT** use for other purposes other than the intended use.
- To disconnect, turn the power switch to 'OFF', then unplug from wall outlet.
- **DO NOT** pour liquids into the dryer.
- **ONLY** turn 'ON' the power after the lid is closed.
- **TURN** 'OFF' the power switch before opening the lid
- **DO NOT** leave the dryer unattended while in use at any time.
- **DO NOT** operate near combustible or pressurized spray cans.
- **DO NOT** use the dryer more than **48** continuous working hours. After a maximum of 48 hours in use, turn **OFF** and unplug the dryer for at least 1 hour.
- Leave a minimum 250 mm (12") open space all around the exterior of dryer.
- The use of unauthorized accessories may cause injuries.
- Store in a dry & clean place. Do not drop, knock or shake the dryer. Rough

handling can break the internal circuit board & diminish product performance.

- Do not open the dryer base as this may cause damage or malfunction. There is no user-serviceable part inside the dryer base.
- Following proper safety and operating instructions is the responsibility of the owner. Failure to use and maintain the dryer in accordance with the instructions outlined in this manual will void the warranty and liability of dryer manufacturer.

WARNING: MISUSE OF TIERTIME PRODUCTS INVOLVES SERIOUS RISKS INCLUDING INJURY AND PROPERTY DAMAGE.

2. INTRODUCTION

The model FD2003 offers an easy and quick way to remove moisture from filaments for better quality of 3D printing. It works with both 1.75mm & 3mm diameter filaments of any filament material.

Model FD2003-220 has a non-polarized plug, which can be plugged into a 220VAC outlet. Model FD2003-120 has a polarized plug (one blade is wider than the other). To reduce the risk of electric shock, this plug will fit in a polarized outlet only one way. If the plug does not fit fully in the outlet, reverse the plug. If it still does not fit, contact a qualified electrician. Do not modify the plug in anyway.

Filament spools with the max outside diameter (**OD**) of 300mm (12") can be used. The dryer can have the following 3 configurations:

- **Dryer Standard Package:**
2 vertically mounted spools with max OD of 200mm (8") each. See Fig.1.
- **Optional Large Spool Kit + Dryer Standard Package:**
1 large vertically mounted spool with max OD of 300mm (12"). See Fig.2
- **Optional Additional Chamber Kit + Dryer Standard Package:**
4 vertically mounted spools with max OD of 200mm (8") each. See Fig.3.

The standard dryer package doesn't include the optional kits, which need to be purchased separately.

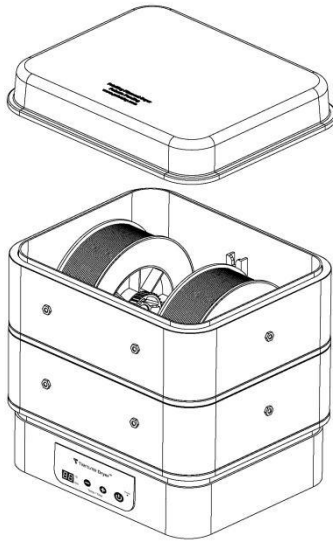

Fig.1 Dryer Standard Package for 2 Spools (max OD 200mm or 8" each)

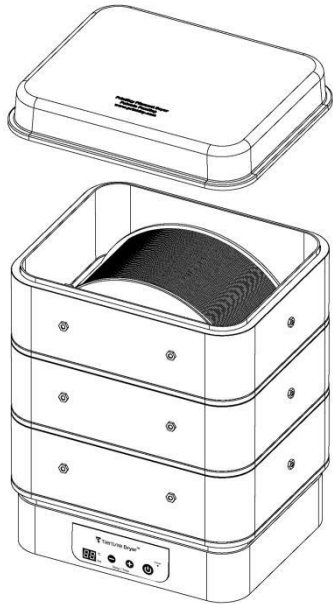

Fig.2 Dryer Used for 1 Large Spool (max OD 300mm or 12")

DESCRIPTION OF PARTS

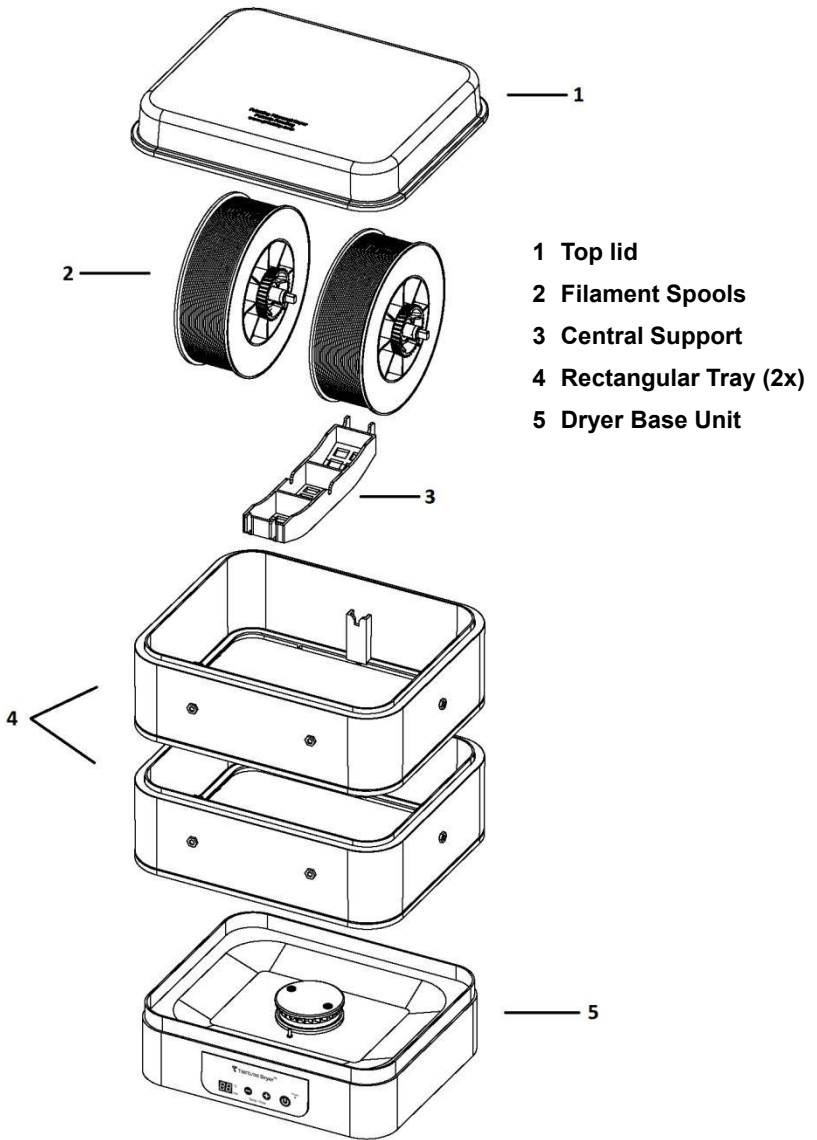

Fig.3 Tiertime Filament Dryer

BEFORE FIRST USE

- Unpack and remove all parts and packaging materials from the carton.
- **DO NOT** plug in the power cord before reading the instructions.
- Wipe the base with a slightly damp cloth. **NEVER IMMERSE THE BASE IN WATER OR ANY OTHER LIQUID.**

3. HOW TO USE

Tiertime filament dryer offers two functions – **Dry** and **Feed+Dry**:

➤ Dry Function

- 1 Prepare filament spools with the mounting rods and mounting adaptors, as shown in the figure below.

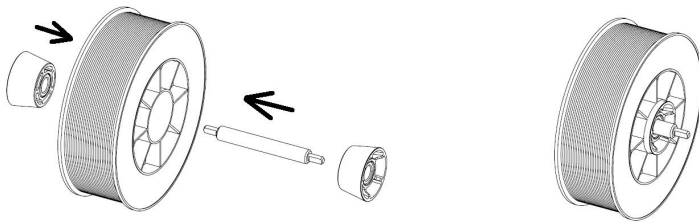

Fig.4 Assemble Filament Spool

- 2 Put filament spools into the dryer with the mounting rod being supported on the slot of the plastic tray and the center support piece.
- 3 Place the dryer base unit on a flat, smooth heat-proof surface. Plug into wall outlet, press ON/OFF switch to turn on and select the appropriate temperature for the filament as indicated in this manual.
- 4 Press "+" and "-" buttons together to enter into the timer setup. Use "+" and "-" button respectively to set the timer (1 - 48 hours) for auto-shut-off.
- 5 When drying is completed, remove filament spools and store them in the filament container if possible with desiccants pouches inside.
- 6 Use power switch to turn off & wait 1 minute to unplug from outlet.
- 7 Follow the instructions in the 'Care and Maintenance' section.

➤ **Feed + Dry Function**

- 1 Follow steps 1 and 2 in the previous section.
- 2 Pass the filament through the holes in the plastic trays and feed it into your 3D printer, it is very important to adjust the dryer's position for a smooth feeding.
- 3 Follow steps 3-6 in the previous section.

RECOMMENDED DRYING TIME

No.	Filaments	Dryer		Drying Time (Hours)
		Temperature		
1	PLA	55°C	(131°F)	> 3
2	ABS	65°C	(149°F)	> 3
3	PETG	65°C	(149°F)	> 3
4	Nylon	75°C	(167°F)	> 12
5	Desiccants	65°C	(149°F)	> 3
6	PVA	45°C	(113°F)	> 10
7	TPU/TPE	55°C	(131°F)	> 4
8	ASA	65°C	(149°F)	> 4
9	PP	55°C	(131°F)	> 6
10	HIPS	65°C	(149°F)	> 4
11	PC	75°C	(167°F)	> 6
12	PEEK	75°C	(167°F)	> 6

These recommendations are made under the following conditions.

*Ambient RH:50% *Ambient Temp:25°C *500g filament spool * Original filament

Actual filament drying time varies due to filament additives, initial water content level and ambient temperature & humidity. If a filament has been exposed in the air for weeks, very likely a lot of moisture has been absorbed and much longer drying time (double the regular drying time) is needed. In addition to drying the filament prior to 3D printing, drying the filament while printing is always recommended.

CARE AND MAINTENANCE

- Turn off the dryer.
- Unplug from the wall outlet.
- If needed, wash the base with a soft, slightly damp cloth or sponge.
- DO NOT allow water or any other liquid to get into the dryer base.
- Make sure the trays and lid are completely dry before replacing them on the base and storing.
- Any other servicing should be performed by an authorized service representative.

4. SPECIFICATIONS

Models	FD2003-120, FD2003-220
Power Supply	110-120VAC, 60Hz, 300W (Model FD2003-120) 220-240VAC, 50Hz, 300W (Model FD2003-220)
Dryer Temperature*	35-75°C with 10°C increment (95-167°F)
Weight	4.5 Kg (8.5 lbs)
Dryer Dimensions	32(W) x 26(L) x 35(H) cm (13x11x16")
Max. Drying Time	48 Hours (Continuously)
Spool Dimensions	Outside Diameter 100-300mm (4-12")
	Height 25-150mm (1-6")
	Mount Hole Diameter 19-58mm (3/4 - 2.3")
	Max. Weight 5Kg (8.8 lbs)

* The temperature inside a dryer varies due to the following factors: (1) ambient temperature; (2) location inside a dryer; (3) how many filament spools and desiccant pouches are in the dryer. Higher ambient temperature means higher temperature inside a dryer. The temperature is higher when close to the hot air outlet. The temperature inside a dryer is higher when drying multiple filament spools and a lot of desiccant pouches.

5. WARRANTY

Tiertime filament dryer is warranted to be free from defect in material and workmanship for a period of ONE year under normal use after its original purchase date. This warranty extends only to the original retail purchaser. If the device should become defective within the warranty period, please contact us for repair or replacement. We reserve the right to replace a defective product with the most comparable product currently available. The entire liability for any defective product shall in no event exceed the purchase price for the defective product. The product liability & warranty **DOES NOT** cover products damaged by the following:

- Misuse, accident, abuse or alteration
- Serviced by unauthorized persons
- Use with unauthorized accessories
- Damage occurs in shipping
- Connect to incorrect current and voltage
- Any other conditions beyond our control

TO THE EXTENT PERMITTED BY LAW, TIERTIME SHALL NOT BE RESPONSIBLE FOR ANY DIRECT OR INDIRECT DAMAGES RESULTING FROM THE USE OR MISUSE OF THE DEVICE INCLUDING ANY GENERAL, INCIDENTAL, SPECIAL, OR CONSEQUENTIAL DAMAGES. ALL IMPLIED REPRESENTATIONS, WARRANTIES OR CONDITIONS INCLUDING BUT NOT LIMITED TO ANY IMPLIED REPRESENTATIONS, WARRANTIES OR CONDITIONS OF FITNESS AND MERCHANTABILITY ARE LIMITED IN DURATION TO ONE YEAR FROM THE DATE OF ORIGINAL PURCHASE.

This warranty gives you specific legal rights, and you may also have other rights that vary depending on your state, province or other jurisdiction. Some jurisdictions do not allow the exclusion or limitation of incidental or consequential damages, or limitations on how long an implied warranty lasts, so the above limitations and exclusions may not apply to you. This warranty does not include the cost of returning shipping.

6. CUSTOMER SUPPORT

The Tiertime filament dryers (Model FD2003-120 and Model FD2003-220) have been respectively certified or in the process of being certified by:



For product updates and more information about Tiertime filament dryers, please contact us at:

www.tiertime.com **tiertime@tiertime.net**