

INTAMSYS

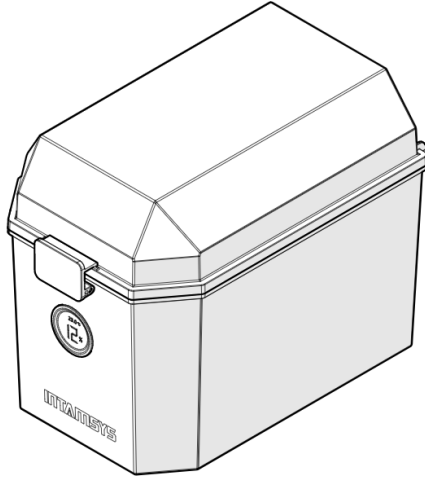

USER MANUAL

INTAM™ Box

1 Service and Safety Notice

1.1 Service

Please contact INTAMSYS customer support for any problem not covered by this guide during your use of the independent filament box (hereinafter referred to as “INTAM™Box”).

Region	E-mail
Asia Pacific	Support_APAC@intamsys.com
Europe, Middle East and Africa	Support_EMEA@intamsys.com
North America / Latin America	Support_America@intamsys.com

1.2 Safety Notice

1. Do not open the drying unit. The desiccant in the drying unit is 4A molecular sieve (Molecular, 4A), it is easy to cause skin and eye irritation.
2. Do not soak the molecular sieve in water.
3. When using an oven to dry the drying unit, be sure to [wear high-temperature gloves](#) before operating.
4. After drying, the drying unit must be cooled to room temperature before putting it into the INTAM™Box, please do not touch the outer surface to [avoid burns](#) during cooling down.
5. When the INTAM™Box works, be sure to close the upper cover of the box and close the latch to avoid long-term exposure of the drying unit to humid air.
6. After the upper cover of the INTAM™Box is fully opened (the rotation angle is close to 100°), do not turn the upper cover at the limit position to avoid damage to the upper cover.

7. Only the specified size of spools can be stored in the box. Do not put the spools with too large diameter into the box to avoid damage to the upper cover and the filament tensioning device.

8. There is a button battery in the hygrometer, please do not dispose of the used button battery in general household garbage, fire or water.

1.3 Precautionary statements for molecular sieves

Please use the drying unit as a whole to avoid dismantling and scattering the molecular sieve. The direct contact of the molecular sieve with the human body can easily cause skin irritation, eye irritation, and respiratory tract irritation.

- **Precaution**

- Wash thoroughly after handling.

- Wear protective gloves, protective mask.

- Avoid breathing dust/fume/gas/mist.

- **Incident Response**

- IF ON SKIN: Wash well with water.

- IF SKIN IRRITATION: Get medical advice/attention.

- IF IN EYES: Rinse cautiously with water for several minutes. Remove contact lenses and continue to rinse.

- IF EYE IRRITATION PERSISTS: Get medical advice/attention.

- IF INHALED: Remove to fresh air and keep comfortable for breathing.

- IF FEEL UNWELL: call a poison center/doctor.

- **Safe Storage**

- Store in a well-ventilated place. Keep container tightly closed.

- **Disposal**

Recycle if possible.

If it cannot be recycled, should be disposed of by incineration.

Should not be disposed of by discharge into water courses.

Dispose of contents/container in accordance with local regulations.

- **Composition Information**

Components: Molecular sieves, 4A.

Concentration or concentration range: 100%

CAS No: 70955-01-0.

Remarks: 4A molecular sieve is a sodium type aluminosilicate, the main crystal pore diameter is 4\AA ($1\text{\AA}=10^{-10}\text{m}$).

2 Introduction

2.1 Specification

Product Name	INTAM™Box
Number of filament spools	2 x 1kg
Spools size	Diameter 200±4mm, width 40-70mm
Filament diameter	1.75mm, 2.85mm
Tube diameter	6mm
Drying time	≤10%RH for 20 days (closed)
Environment temperature	-10°C~60°C(14 °F-140 °F)
Desiccant	4A molecular sieve, 900g
Regeneration of desiccant	The drying unit is placed in drying oven, and dried at 200°C (392°F) for 2 hours
Product size	315 x 205 x 257mm
Product weight	2.45kg

2.2 Packing List

INTAM™Box	×1
Molecular sieve drying unit	×1
Button battery	×1
Tube plug	×2
User manual	×1
Filament tube (φ6mm)	×2
Heat resistant gloves	×1

2.3 Components

1. There are sealing rings and latches around the INTAM™Box to ensure sealing.
2. The INTAM™Box is equipped with a drying unit, filled with 4A molecular sieve desiccant, which can ensure the low humidity environment inside the box.
3. The upper cover of the INTAM™Box is equipped with an anti-tangle spanner: to ensure that the filament will not tangle during printing; when the filament in the spool is exhausted, the spool will not be easily pulled down.

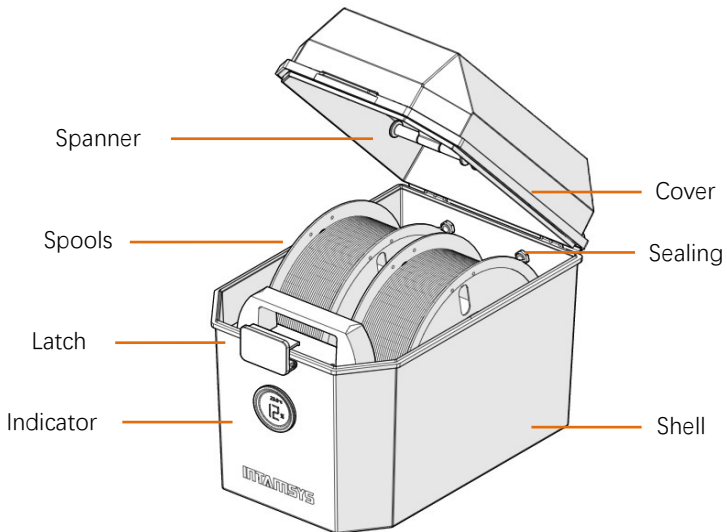

Figure 2.1 Schematic diagram of INTAM™Box

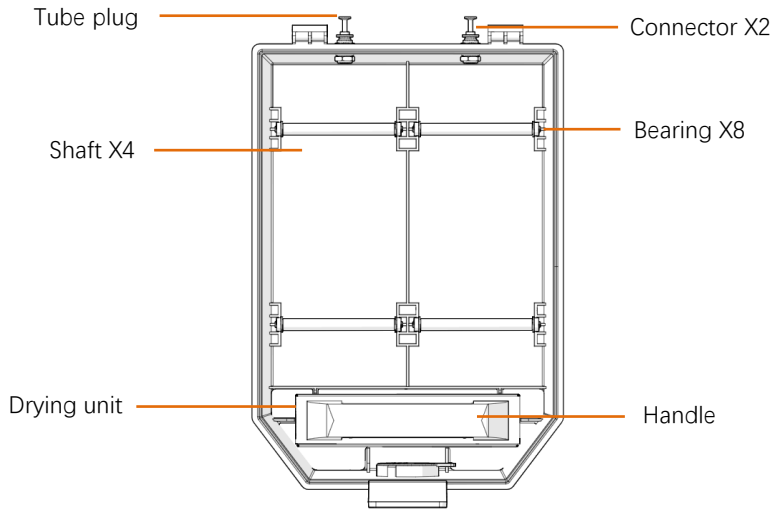

Figure 2.2 Top view of the INTAM™ Box

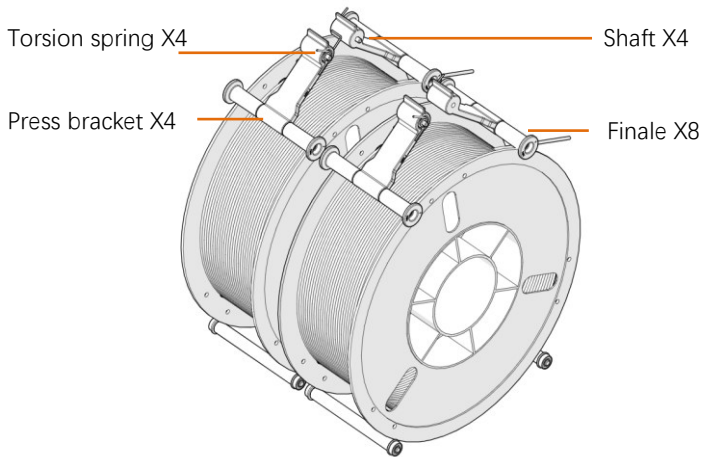

Figure 2.3 Schematic diagram of the anti-tangle spanner

3 Operation

3.1 Installing the filament tube

Define that tube must go all the way through the coupler.

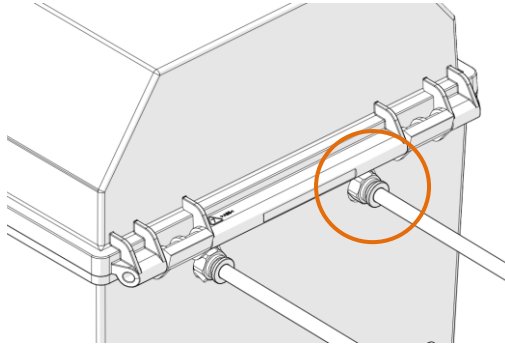

Figure 3.1 Schematic diagram of installing the filament tube

If you don't print, pull out the filament tube, and block 2 connectors with tube plugs, filaments can be stored in a sealed environment for longer time.

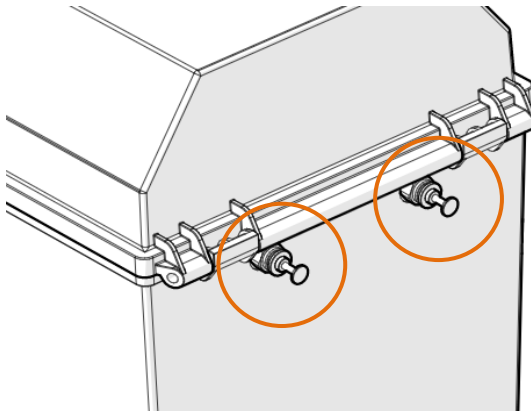

Figure 3.2 Schematic diagram of installing the tube plug

3.2 Put in/out the spools

Put in the spools: unlock the latch, open the upper cover, put the spools on the shaft of the box as shown, and then pass the filament through the quick connector. After manual loading is completed, close the cover and lock the latch.

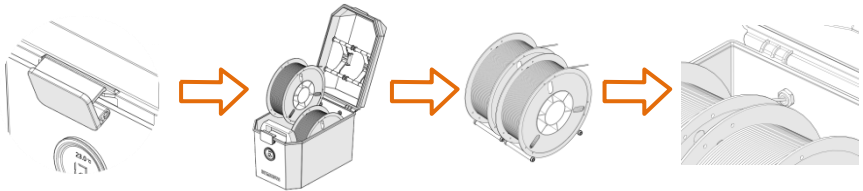

Figure 3.3 Schematic diagram of put in the spools

Take out the spools: unlock the latch, open the upper cover, rotate the spool in the direction shown (counterclockwise), and take out the spool when the filament is completely withdrawn from tube.

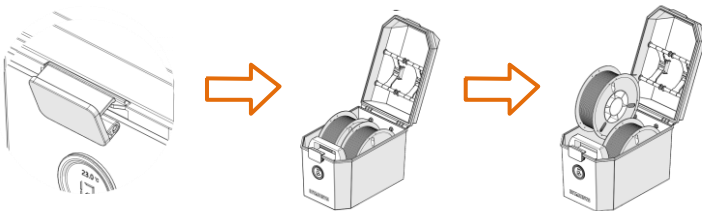

Figure 3.4 Schematic diagram of take out the spools

3.3 Regeneration of the drying unit

Conditions: When the box is closed (> 1 day), and the humidity of indicator $> 20\%$, then the molecular sieve in the drying unit needs to be dried.

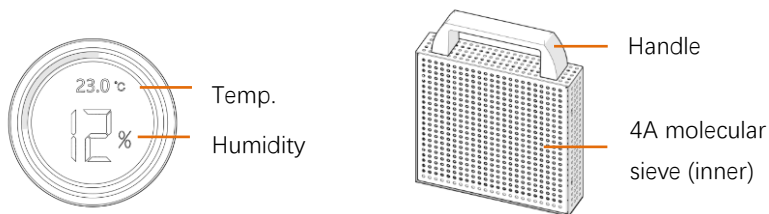

Figure 3.5 Indicator and drying unit

Drying process: Open the cover of the box, take out drying unit, put it into drying oven (200°C/392°F), and dry it for 2 hours (it can also be dried for a longer time); wear high-temperature resistant gloves (beware of burns), take drying unit out from oven, after cooling to room temperature, put it back to the INTAM™Box.

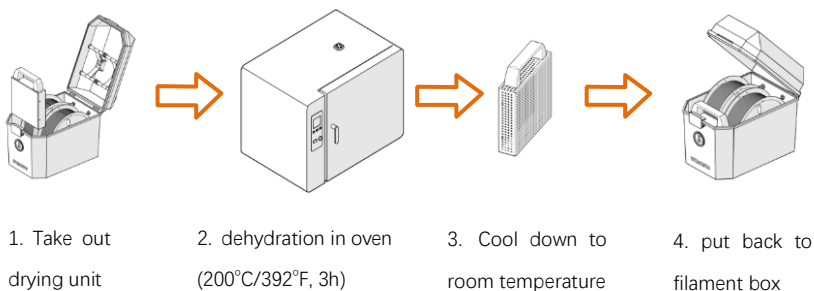

Figure 3.6 Molecular sieve drying and regeneration

3.4 Safety instructions in drying process

1. When using oven to dry the drying unit, be sure to **wear high-temperature gloves** before operating;
2. After drying, the drying unit must be cooled to room temperature before putting it back into the INTAM™Box. When the drying box is cooling, do not touch the outer surface to **avoid burns**.

3.5 Replacing the button battery

INTAMSYS has installed a battery for the indicator, and a new button battery (LR44) is included. When the indicator is low in power (display abnormal), push the back of the button battery in the direction shown in the figure, and replace with a new one.

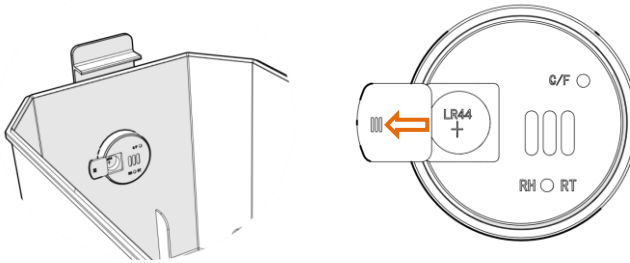

Figure 3.7 Button battery replacement

4 Warranty Instructions

4.1 Warranty period

Items		Warranty duration
INTAM™Box	Body	1 year
	Drying unit	1 year
	Indicator	1 year

4.2 Non-warranty regulations

1. Damage caused by improper use, maintenance or storage;
2. Damage caused by natural disasters such as: fire, flood, earthquake;
3. Damage caused by private demolition;
4. Warranty certificates do not conform to the product, altered or

forged;

5. Service items or contents beyond the warranty period or not promised by the manufacturer for free;

6. The performance indicators or technical parameters meet the product design and specification standards.



www.intamsys.com

info@intamsys.com

FOLLOW INTAMSYS ON



HEADQUARTERS:

INTAMSYS TECHNOLOGY CO., LTD.

Building E11, No.3188 Xiupu Road, Shanghai, China

EMEA Region branch:

INTAMSYS Technology GmbH

Zeppelinstr. 35,

73760 Ostfildern

Deutschland

AMERICAS Region branch:

INTAMSYS Technology Inc.

11479 Valley View Road

Eden Prairie, MN. 55344

United States

Copyright ©2023 INTAMSYS Technology. All rights reserved. The information at hand is provided as available at the time of printing, INTAMSYS reserves the right to change any information without updating this publication.